

SP RR10 RE-REEVING MACHINE & MANUAL TRAVERSE

For reels up to 96" O.D. x 60" wide x 10,000 lbs. load capacity

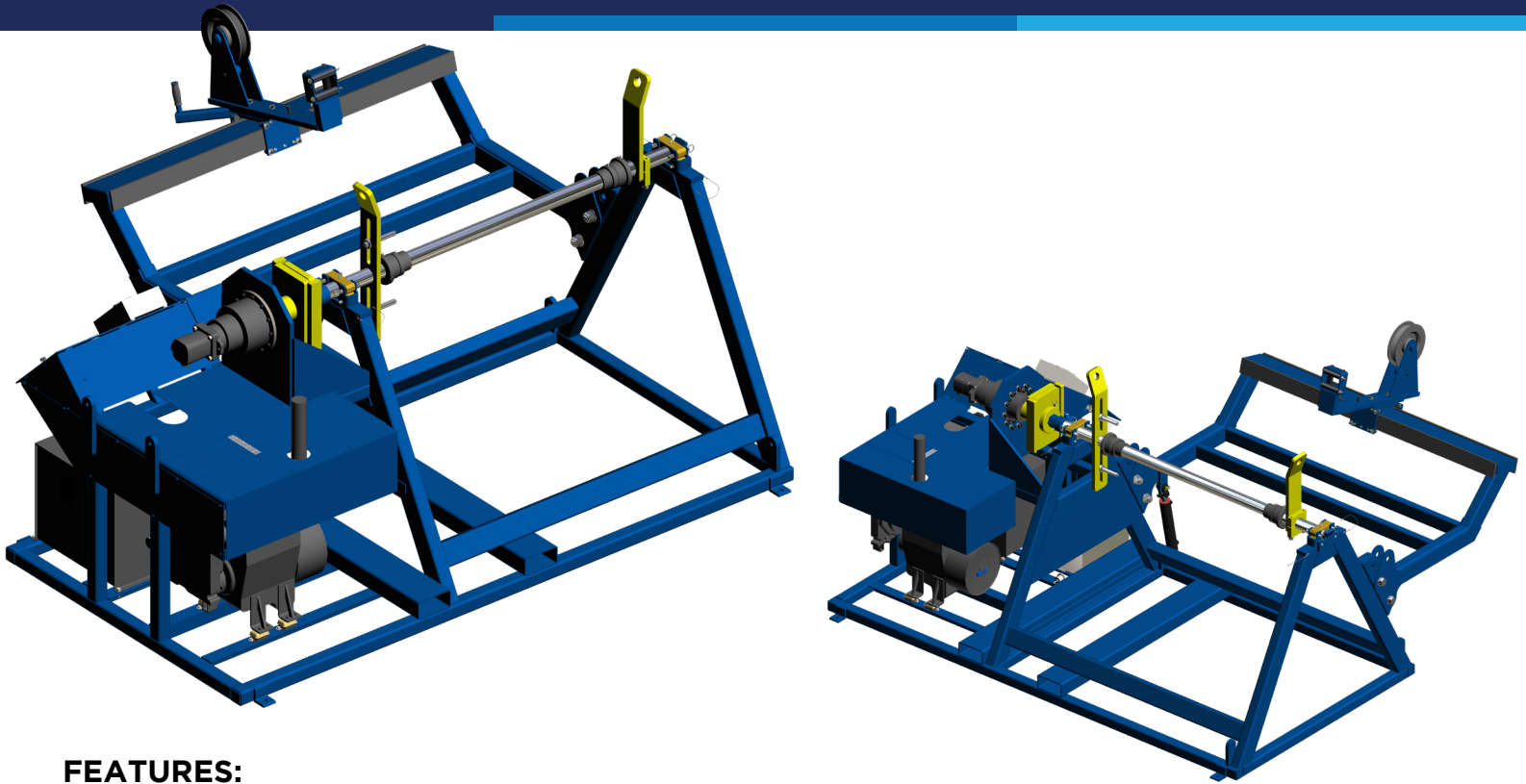

FEATURES:

- Heavy duty structural steel main frame construction with bolt down floor flanges, forklift base and lift eyes
- 3" dia. "drop-in" Steel reel shaft with bronze bearing assemblies, reel locking clamp and loading bar
- Bushings for 4" and 5" arbor holes
- Drive arm with dual adjustable drive pins and integral loading bar
- Safety shaft latches
- Outdoor environment package, which includes:
 - Primer with two coats of enamel paint
 - Stainless or plated hardware
 - Power unit rain shield (Includes stainless steel reel shaft and drive pins)
- One (1) 22 HP Electric start Kubota or Kohler (depends on availability) diesel powered hydraulic system to provide tensioned controlled pay-out and take-up operations. Capable of providing up to 100,000 in/lbs. torque, 0 to approximately 8 RPM. Capable of providing up to 6,666 lbs. of line tension at a 30" drum diameter.
- Manual hand valve with spring return to center operation for speed and direction control
- Hand operated pressure relief valve with gauge to adjust torque
- Slide Traverse system